

Model T - CRD CR Dashpot

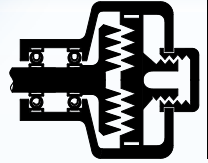

Dimensions in mm.

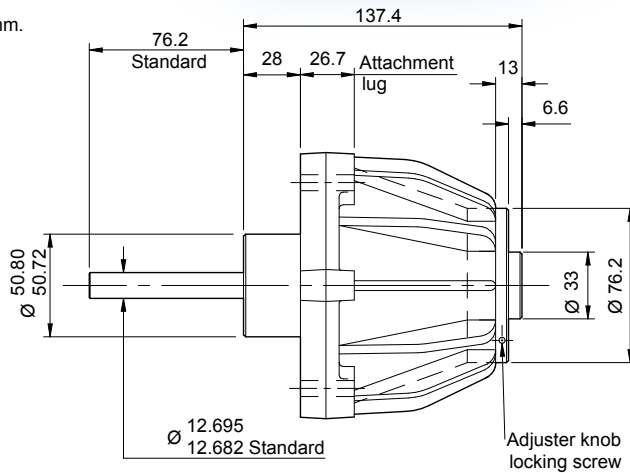
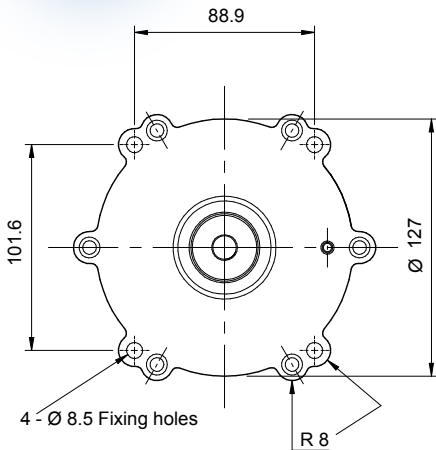

Specification

Rate

Adjustable - see curves left ($\pm 10\%$)

Adjustment allows the rate to be varied down to 1/4 of the maximum values, for any speed of rotation.

The adjuster knob, although marked for reference, is not normally calibrated.

Fixed rate version available - contact Kinetrol

Max. safe torque
398 lbf.ins / 45 Nm

Max. shaft side load
41 lbf / 183 N

Ambient temperature range
0°C to 60°C

Frictional torque
0.5 lbf.ins / 0.056 Nm typical

Shaft material
High tensile steel
605M36(T)

Body material
Cast Aluminium LM 4M

Weight
5.27 lbs / 2.39 kg

SPEED - Rev. / min

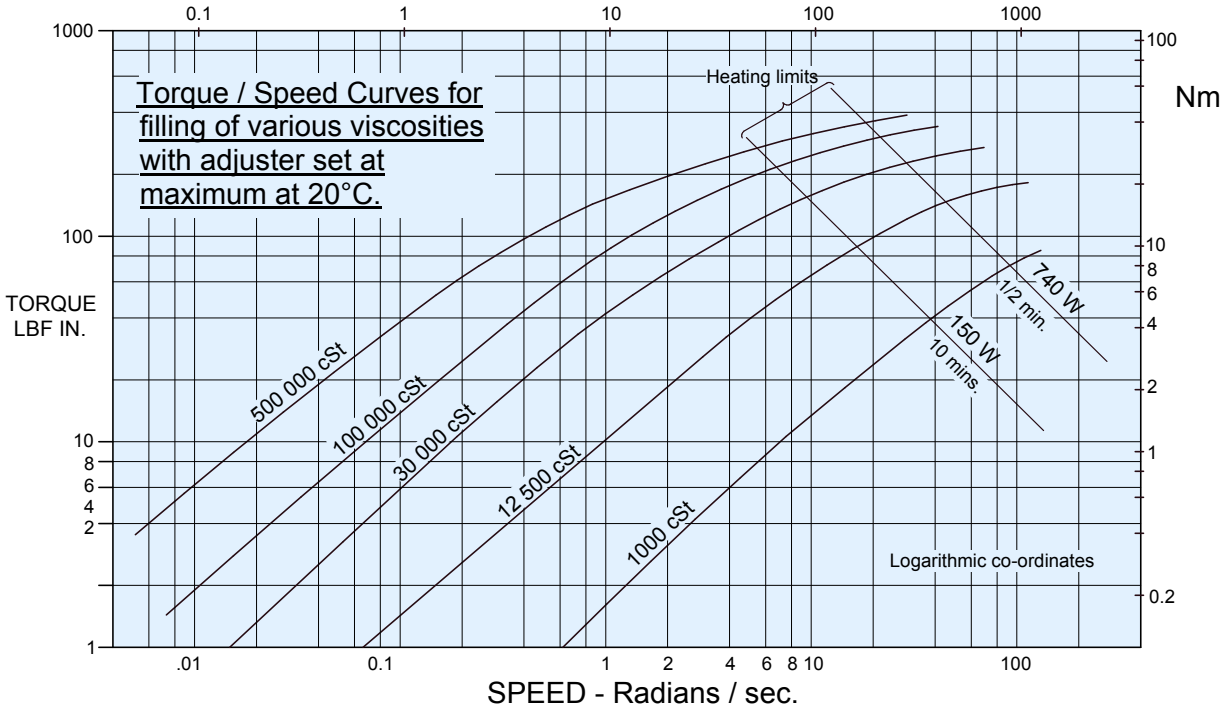

Viscosities Available

1,000; 12,500; 30,000; 100,000; 500,000 cSt.

Specification of fluid viscosity provides torque/speed characteristics shown by the curves above.

Ordering Codes

T - CRD - (Filling Viscosity)

Example:

T - CRD - 100,000 has a 100,000 cSt filling.